

iBend 
SERVO PRESS BRAKE



MVD



We produced our first machine.



We started to produce Heavy duty press brakes and guillotine shears.



We produced the first Tandem Press Brake in Turkey.



We started manufacturing CNC Hydraulic Turret Punch machines.



We started manufacturing Plasma Cutting Machines.



We started manufacturing Hybrid Press Brake.



We started manufacturing Servo Press Brake.

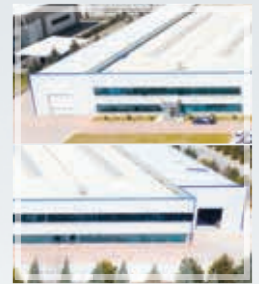

Thanks to MVD Academy, we graduate professional work-mates and experts.

1950

1974

1994

2003

2010

2015

2018

2021

1971

1981

2001

2011

2017

2020



We produced the first sheet metal working machine "Perforation Press".



We moved to new factory and started to produce 4 roll bending expanded metal press machines.



We finalized the CE conformity procedures and had marked CE to MVD machines.

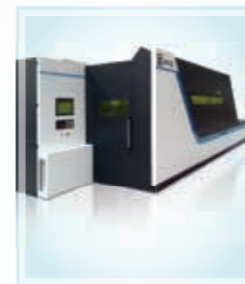

We started manufacturing Fiber Laser Cutting Machines.



We established the Research and Development Center certified by the Ministry of Industry and Technology.



We established innovation platform.

Trusted Partner



VALUES

Result: We set clear, specific goals, and we deliver them. For this purpose, we equip our people with the best tools and equipment they need.

Responsiveness: We are aware that doing business is an action between people. We listen with full attention, empathize and reply in the fastest and most accurate way.

Respect: We respect people, nature, the past and the future.

MISSION

We design, produce and deliver safe, high quality and high-efficient machine tools for our customers success.

VISION

Become the world's most reliable leading brand by continuous growth, and to provide sustainability as the 1st choice of the customers with the product and service quality.

ABOUT US

MVD is a company dedicated to the developing industry with its superior quality understanding and technical service provided worldwide.

Since 1994, MVD has become a significant manufacturing company with its exports to every country in the metalworking machinery industry.

In addition, it has an active role in presenting its machines in more than 90 countries with distributors and partners to the world market. It is one of Turkey's top 5 exporters and wants to lead essential developments in the industry and continue its leadership.

MVD

SERVO PRESS BRAKE

Ensure Speed, Efficiency, High Energy Saving

Servo Press Brakes as MVD Machine;

In different models and tonnages, we offer our customers the highest quality next generation bending technology.

With our daily "Servo Press Brake" product range, we aim to expand the use of Servo Electric Press Brake Presses, which are user and environmentally friendly for a sustainable world.

To achieve this goal: outside of quality production and service support; In design and production, we are based on reliability, durability and precision. Machines are easy to use but also prepared for user errors.

With "Industry 4.0" compliance, it supports and contributes to intelligent manufacturing processes.





Your Most Profitable Investment



iBend

SERVO PRESS BRAKE

The newest and fastest in its class.



Equipped to easily do the most complex tasks with the advanced CNC Controller.

It allows to make precise bends in different stroke sizes.

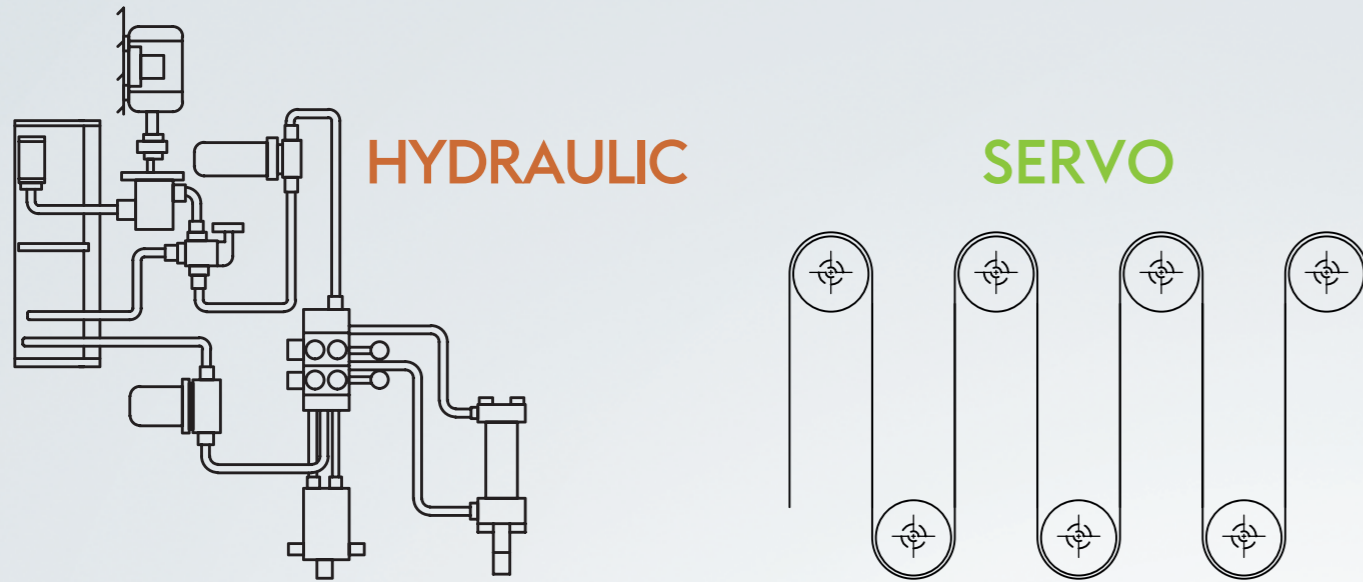

ADVANTAGES OF SERVO PRESS BRAKE



	 HYDRAULIC	 SERVO
F Bending Force	Up to 2000 Tons	Up to 320 Tons
 Energy Efficiency	Middle	High
 Maintenance Requirement	Periodic	Rarely
 Maintenance Cost	Low	Lower
 Positioning Accuracy	High	Higher
 Machine Noise	Middle	Low
 Pump Noise	Yes	No
 Environmental Pollution	Normal	No
 Heat Generation	High	No
 Remote Connection	Yes	Yes
 System Hardware	Complex	Compact

Lower energy consumption

Hydraulic Press Brake saves up to 50% energy according to hydraulic press brakes.

More ergonomic and compact design

Thanks to its ergonomic design, it offers a more comfortable way of working for the operator. Thanks to the compact design in the S Series, it is possible to easily carry it to the desired work area with the forklift transport feature.

Lower maintenance and production costs

Since the hydraulic system and cylinder are not used and are fully electric, maintenance costs are low and provide the possibility of production at lower costs.

More perfect bend results

Thanks to more precise positioning and repeatability, bending results are better quality and more reliable. In this way, lower per-piece costs are reached because secondary operations are not required.

Faster

Due to the lack of time losses in the hydraulic system, the reaction time is shorter.

This allows you to be 30% faster and work more efficiently.

Shorter bending processes

Thanks to its higher acceleration and rapid reaction, the bending process is shorter and provides more part processing.

Lower sound

Servo Press Brake works quieter than presses. For this reason, it reduces the sound pollution for the operator and provides a better working environment.

Fewer parts and connections

It does not create environmental pollution due to the use of oil and the operation of it with 100% electric power as no oil filter is required. In this way, it contributes to the environment and your corporate economy.

Sales Cost Scenario (Based on full time working)			
EN	Hydraulic Press Brake A40-1250	Servo Screw Driven Press Brake S40-1250	
	Bend [Qty]	Bend [Qty]	Difference
Daily [8 Hours]	2.880	3.456 (20 % faster)	576
Monthly [20 Days]	57.600	69.120	11.520
Annual [240 Days]	691.200	829.440	138.240
Profit per bend [0.25 €]	172.800,00 €	207.360,00 €	34.560,00 €

Operator costs scenario (Based on full time working)			
Maintenance [Annual]	3.000,00 €	1.000,00 €	2.000,00 €
Operator costs [12 Months]	50.000,00 €	40.000,00 € (20 % lower)	10.000,00 €
Total	53.000,00 €	41.000,00 €	12.000,00 €
Annual Profit			46.560,00 €

Worked for illustration purposes. Based on ideal working situation.

Per minute: 6 Bends

Daily: 8 hours of work

Monthly: 20 days of work

Profit per bend [0.25 €]

NEW GENERATION ELECTRIC SERVO PRESS BRAKE

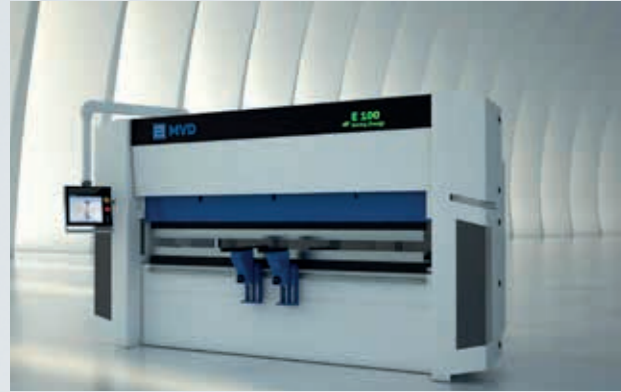

Body Structure

- Robust monoblock body with O-Type or C-Type frame range provides high precision in bending operations.
- Compact Body: With quick installation and easy handling, you can install and adapt to your mass production line according to your needs.



CNC Unit

- ESA S 630 Controller (Standard)
- 10" colour touchscreen
- Automatic bending sequence
- Easy-to-program 2D graphics display.
- Up to 4 Axis (Y1, Y2, X and R)

Other recommended Controllers:
ESA S 660 3D Control Unit (Optional)
Delem DA 53T, DA58T, DA66T (Optional)



Front Supports / Work Table

- Strong front support arms, linear guide and bearing system can be easily moved left and right and fixed in the desired position. (Standard)
- Thanks to its foldable front table, it allows the operator to work both standing and sitting. (Optional)

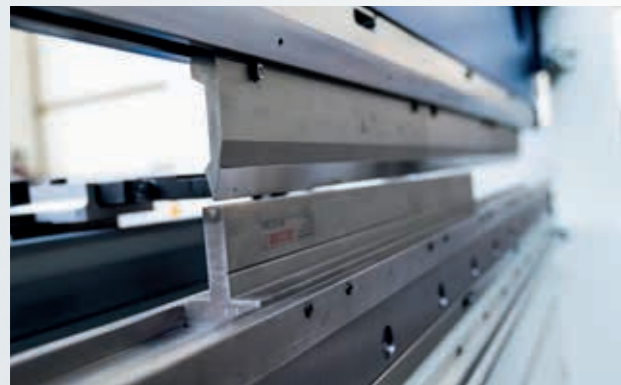

Die Holders and Tools

- European Type tool holder and die holder systems (Standard)
- Wila mechanical, pneumatic and hydraulic die holder system (Optional)

Back Gauge

- MVD X+R Back Gauge (2 Axis) Is a usable solution for easier machining of parts. (Standard)
- MVD X+R+Z1+Z2 Backgauge provides motion thanks to Servo motor that acts according to the program in the cycle you programmed on the Z1 & Z2 Control Unit (Optional)
- With the help of high-precision and high-quality Servo motors, the backgauge can be positioned quickly and precisely.



Security System

- Designed to European CE standards and has innovative safety features.



Manual or Motorized Crowning

- The crowning system ensures that the yawning of the lower and upper table due to the applied force eliminates the effect of the sheet metal on the bending angle. This correction is carried out in real time and with the latest sensors thanks to motorized crowning. Crowning allows you to achieve more precise and constant bending results in long parts.

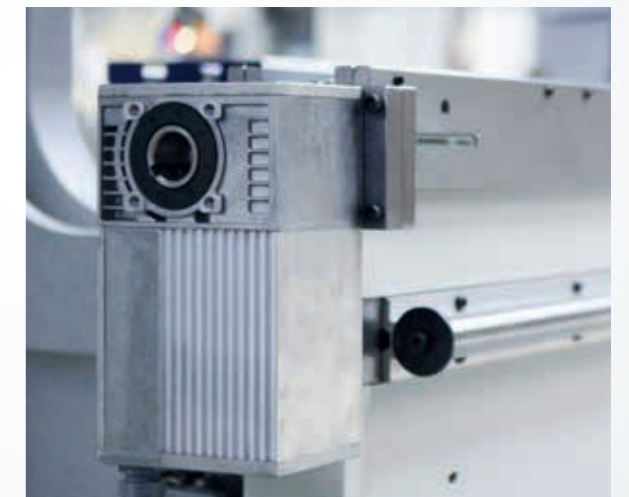

E-Series

Belt Driven Servo Press Brake

Bending operations with belt and pulley movement system are driven by 2 synchronous operated servo motors.

Thanks to the springs that support the top table, energy is saved in return movements.

In belt driven servo press brakes, O-Type body system is used instead of C-Type body system. Therefore, the deformation that may occur in high force applications is prevented thanks to the O-Type body and more precise bending results are obtained.

BELT DRIVEN SERVO PRESS BRAKES

- Faster
- Shorter bending processes
- More excellent bend results
- Lower maintenance and production costs
- Quieter
- Less energy consumption

RECOMMENDED CONTROL UNITS

ESA S660W



19 inc touch screen control unit
3D - 3-12 Axis

ESA S640
ESA S650

DELEM DA66T



17 inc touch screen control unit
2D - 3-8 Axis

DELEM 53T,
DELEM 58T

VisiPac 19



19 inc touch screen control unit
3D - 3-12 Axis

CypTouch 15



Standart
X +R Eksen Arka Dayama



Standart
GIVI Optik Lineer Cetvel



Standart
Çabuk Sıkma

Stroke
300 mm

Throat "O"-Type

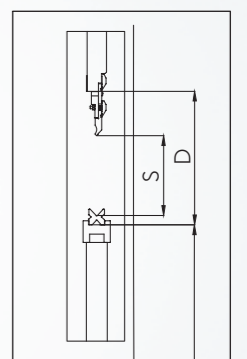

BE THE WINNER OF EVERY DAY



Standard Features

1. Y1, Y2, X, R - 4 Axis CNC
2. ESA S630 Controller
3. Stroke 300 mm , Throat Depth "O" - Type
4. Servo motorized back gauge - Accuracy ± 0.03 mm - X: 750 mm
5. Back gauge finger 2 pcs, 3 stages
6. Quick clamping promecams
7. Narrow bottom table specific to MVD (European type)
8. Standard punch tool ES 1260 (H: 67 mm, 85°, R: 0.8 mm)
9. Standard die tool ES 2067 (60x60 mm, 4-channel V=16-22-35-50 mm, 85°, H: 60 mm)
10. High quality and precision linear rulers
11. Laser beam front security system
12. Led lighting
13. Sliding front support system
14. GIVI optic linear ruler (0.005 mm untied)
15. Double-switch pedal

Optional Features

1. Original WILA wedge bottom table crowning system
2. AKAS or DSP laser beam front safety system
3. Additional back gauge fingers
4. MVD back gauge (X+ R, starting from 4-6-8 axis back gauge options Z1, Z2, X5, ATFL)
5. MVD bending support AP
6. UNIMEC back gauge (X+ R, starting from 4-6-8 axis back gauge options Z1, Z2, X5, ATFL)
7. UNIMEC bending support AP
8. WILA hydraulic top and bottom die clamping

Belt Driven Servo Press Brake Specifications

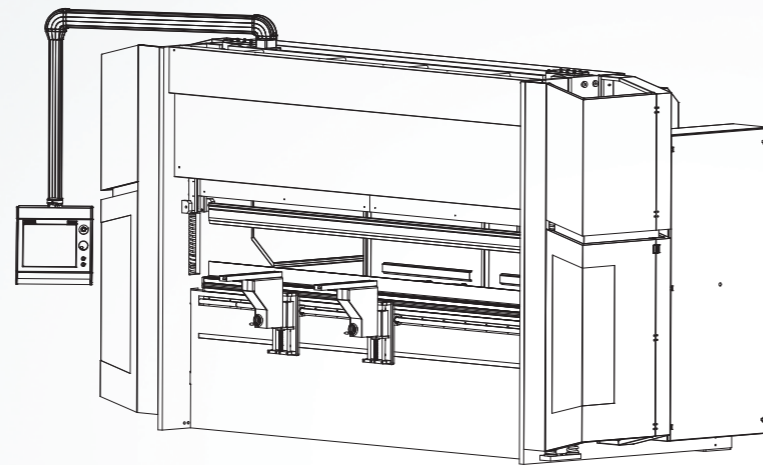
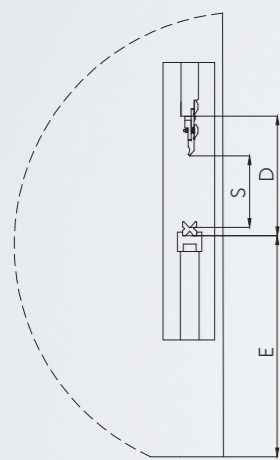
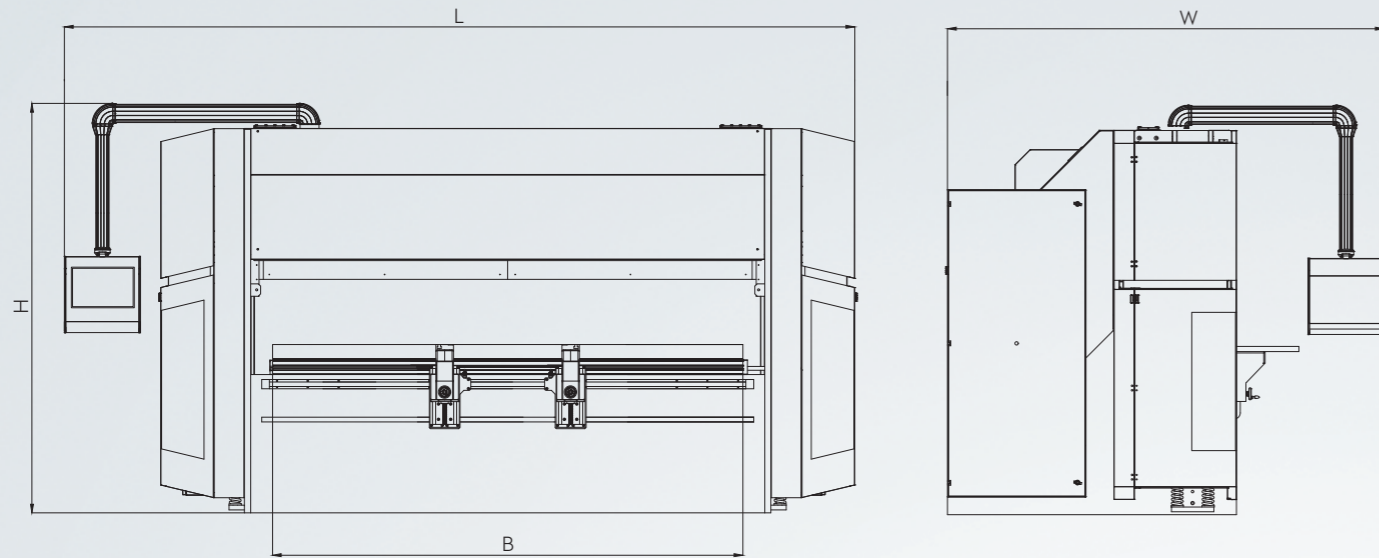

Model	Unit	E80	E100	E130	E130	E160	E160	E200
Bending Length (B)	mm	2600	3100	3100	4100	3100	4100	4100
Bending Force (Ton)	Ton	80	100	130	130	160	160	200
Stroke (S)	mm	300	300	300	300	260	260	260
Throat depth (T)	mm	0-Tipi	0-Tipi	0-Tipi	0-Tipi	0-Tipi	0-Tipi	0-Tipi
Daylight (D)	mm	505	505	505	505	465	465	465
Table Height (E)	mm	900	900	900	900	900	900	900
Approach Speed	mm/s	100	95	85	75	95	85	70
Bending Speed	mm/s CE Norm	10-20	10-20	10-20	10-20	10-20	10-20	10-20
Return Speed	mm/s	100	95	85	75	95	85	70
Length	mm	3750	4275	4275	5275	4285	5300	5050
Width	mm	1900	1950	1950	1950	1950	2000	2000
Height	mm	2500	2500	2500	2500	2500	2550	2650
Weight	kg	6200	7150	8700	11000	12500	14300	17000
Main Motor	kW	11.5	11.5	15.5	15.5	22.0	22.0	25.5
Motor Count	pcs	2	2	2	2	2	2	2
Back gauge finger	pcs	2	2	2	2	2	2	2
X (Axis Speed)	mm/s	250	250	250	250	250	250	250
R (Axis Speed)	mm/s	100	100	100	100	100	100	100
Z1 (Axis Speed)	mm/s	450	450	450	450	450	450	450

*Bending speeds above 10 mm/s are used only in robotic applications due to "CE Norms".

**See the side page for measurement details.

***Specifications may change without notice.

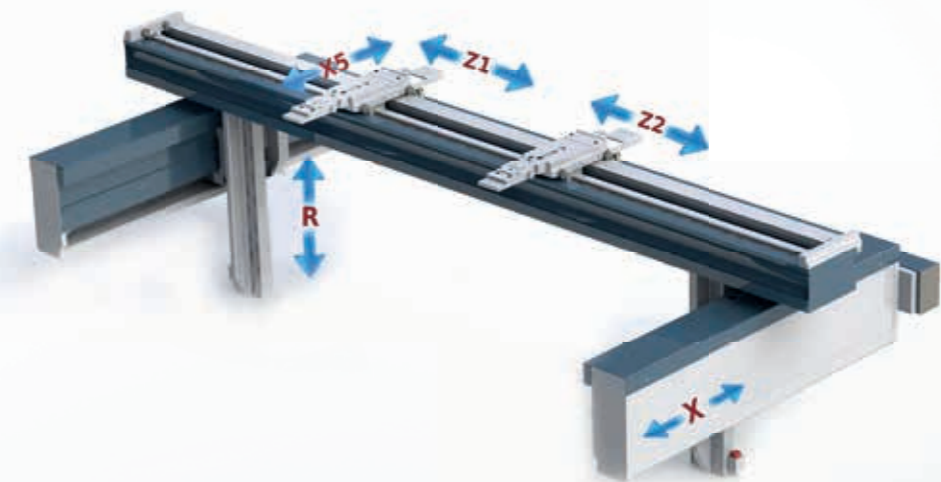

S-Series

Screw Driven Servo Press Brake

Rotational movement from servo motors and the torque effect is transferred to the screw shaft and nut system. Thus, the bending power is achieved with the downward movement of the top table.

SCREW DRIVEN SERVO PRESS BRAKE

- Faster
- Shorter bending processes
- More excellent bend results
- Lower maintenance and production costs
- Quieter
- Less energy consumption

BIG SOLUTION FOR SMALL PARTS



Standard Features

1. Y1, Y2, X, R - 4 Axis CNC
2. ESA S630 Controller
3. Stroke 275 - 310 mm, Throat Depth 300 mm
4. Servo motorized back gauge - accuracy ± 0.03 mm - X: 750 mm
5. Back gauge finger 2 pcs, 3 stages
6. Quick clamping promecam
7. Narrow bottom table specific to MVD (European type)
8. Standard punch tool ES 1260 (H: 67 mm, 85°, R: 0.8 mm)
9. Standard die tool ES 2067 (60x60 mm, 4-channel V=16-22-35-50 mm, 85°, H: 60 mm)
10. High quality and precision linear rulers
11. Laser beam front safety system
12. Led lighting
13. Sliding front support system
14. Single pedal

Optional Features

1. CE conformity - AKAS or DSP Laser beam front safety system
2. UNIMEC back gauge
3. Front working table

RECOMMENDED CONTROL UNITS

ESA S640



15 inc touch screen controller
2D - 3-6 Axis
(Standard)

ESA S650
ESA S660W

DELEM 53T,



10 inc touch screen controller
2D - 3-4 Axis
(Standard)

DELEM 58T
DELEM DA66T

CypTouch 15



15 inc touch screen control unit
2D - 3-4 Axis
(Standard)

VisiPac 19



Standart
X + R Axis Back Gauge



Standart
GIVI Optic Linear Ruler



Standart
Quick clamping

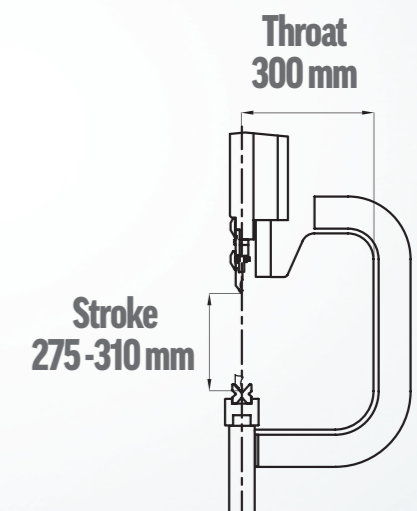

Screw Driven Servo Press Brake Technical Specifications

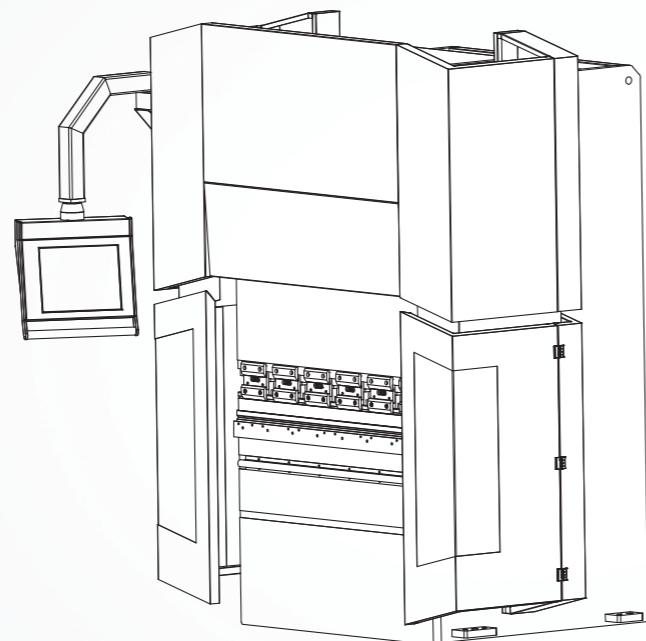
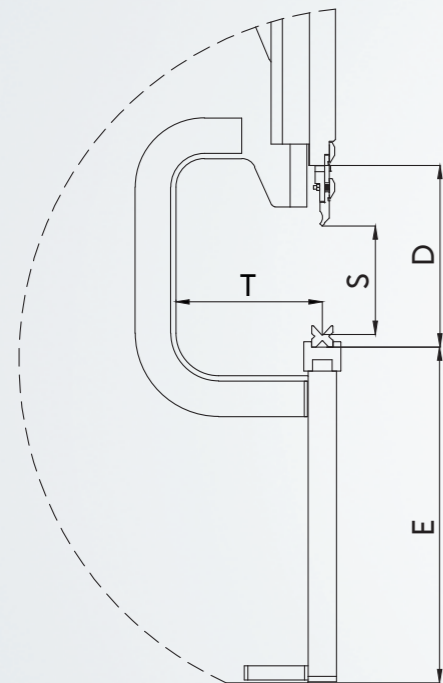
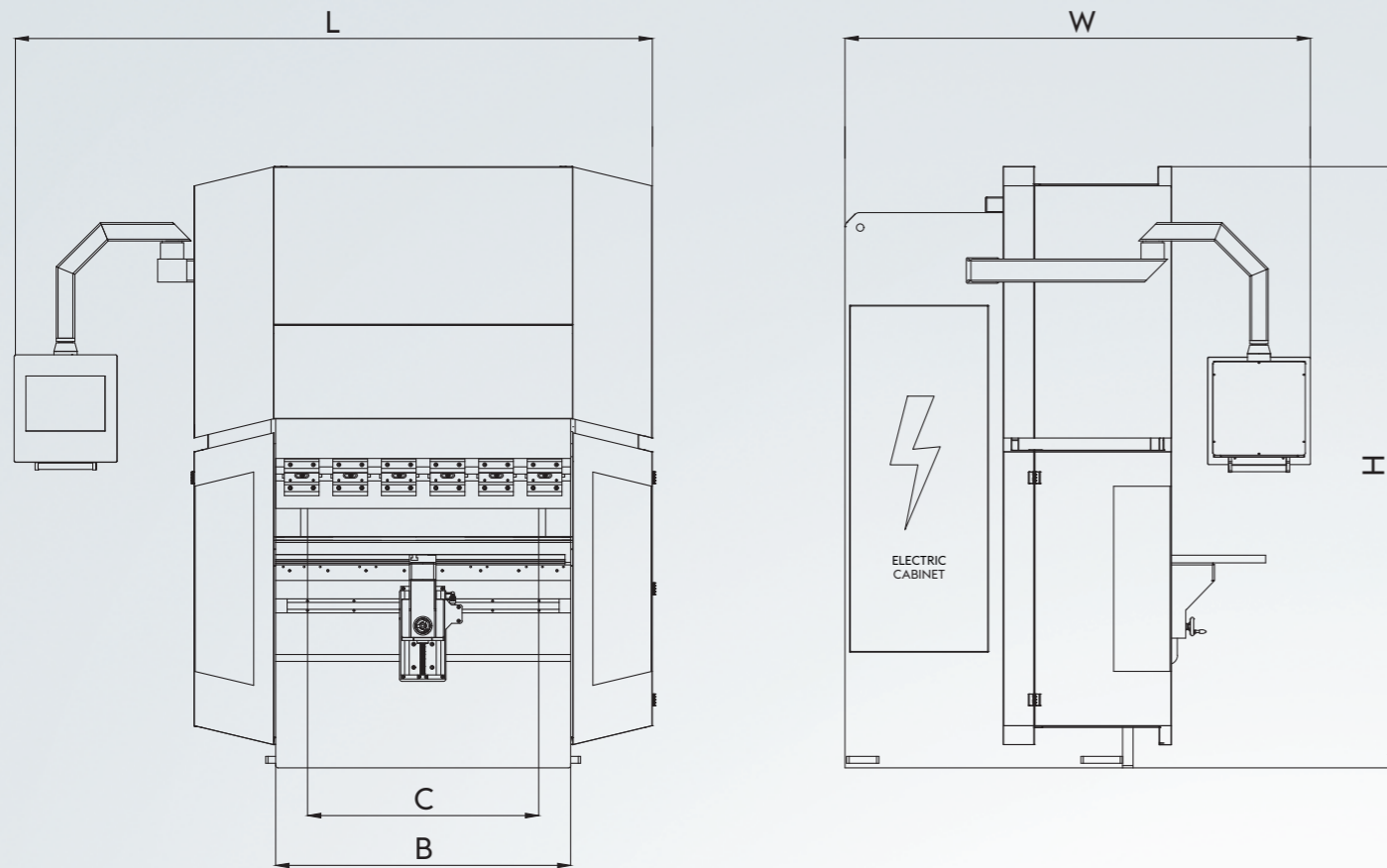

Model	Unit	Screw Driven		
		E20	E40	E60
Bending Length	mm	950	1250	2100
Bending Force (Ton)	Ton	20	40	60
Max. Stroke (S)	mm	210	210	210
Throat Depth (T)	mm	300	300	300
Daylight (D)	mm	410	410	410
Approach Speed	mm/s	150	150	150
Bending Speed	mm/s CE Norm	10-20	10-20	10-20
Return Speed	mm/s	150	150	150
Length	mm	1610	1960	2840
Width	mm	1350	1450	1450
Height	mm	2570	2610	2610
Weight	kg	2900	4000	5300
Main Motor	kW	4,3 kW	2 x 4,3 kW	2 x 7 kW
Motor Count	pcs	2	2	2
Back Gauge Finger	pcs	2	2	2
X Axis (750 mm)	mm/s	250	250	250
R Axis (250 mm)	mm/s	100	100	100
Z1 Axis	mm/s	450	450	450

*Bending speeds above 10 mm/s are used only in robotic applications due to "CE Norms".

**See the side page for measurement details.

***Specifications may change without notice.

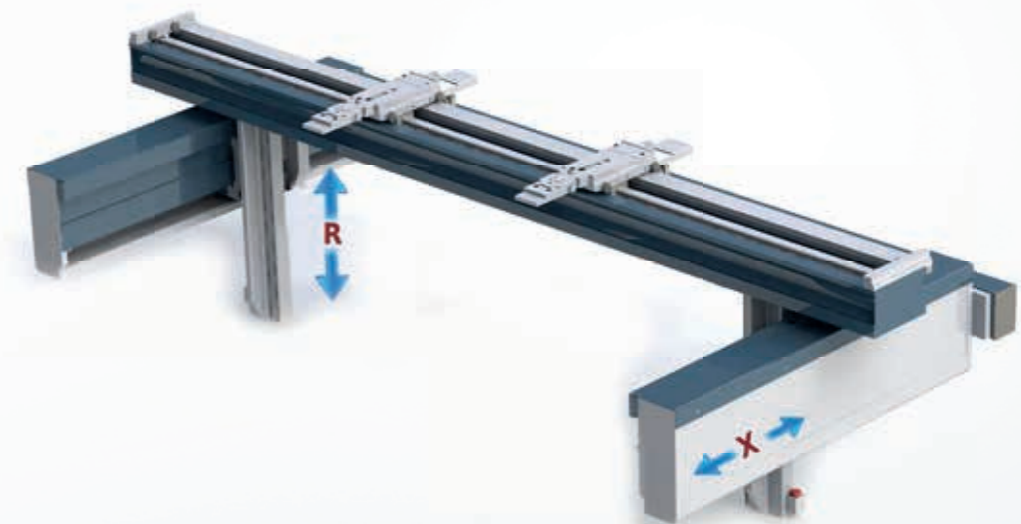

CONTROL UNITS



ESA S 630
3-4 Axis
Standard

- 10 inc 2D Touchscreen
- Manual bending sequence and collision check calculation
- Dead point and Crowning calculation
- 2D Drawing



ESA S 640
3-6 Axis
Option

- 15 inc 2D Touchscreen
- Automatic bending sequence and collision check calculation
- Dead point and Crowning calculation
- 2D Drawing



ESA S 650
4-8 Axis
Option

- 15 inc 2D Touchscreen
- Automatic bending sequence and collision check calculation
- Dead point and Crowning calculation
- Flash Disk input
- Fiber optic interface
- 2D Drawing
- Bending management



ESA S 660W
Option

- 19 inc 4:3 high resolution 3D Touchscreen
- 2.5" 20GB or more hard disk support
- Ability to draw 3D - Transfer DXF files
- Automatic bending sequence and collision check calculation
- Bending management - Dead point and Crowning calculation
- Remote access - Windows 7 operating system"

CNC units, which have the latest technology system, offer high precision bending. Pattern Ease of use for the operator by supporting tool holder systems and multi-axis back gauge systems. It helps to achieve excellent results.

- 10 inc 2D Touchscreen
- 2D Drawing, view, bending simulation
- User friendly - 1 GB Storage
- Semi-Auto bending sequence and collision control calculation
- Deadpoint and motorized calculation
- Backup data - Resolve issues via remote access

DELEM DA-53T
3-4 Axis
Option



- 15 inc 2D touchscreen
- 2D Drawing, view, bending simulation
- User friendly - 1 GB Storage
- Auto bending sequence and collision control calculation
- Deadpoint and motorized calculation
- Backup data - Resolve issues via remote access

DELEM DA-58T
3-4 Axis
Option



- 17 inc 2D Touchscreen
- 2D drawing, 3D view, bending simulation (Option)
- User friendly - 1 GB Storage
- Auto bending sequence and collision control calculation
- Laser angle measurement system and correction function (Option)
- AP Bending support (Option)
- Deadpoint and motorized calculation
- Special application support
- Backup data - Resolve issues via remote access

DELEM DA-66T
3-8 Axis
Option



- 17 inc 2D Touchscreen
- 2D drawing, 3D view, bending simulation
- User friendly - 2 GB Storage
- Auto bending sequence and collision control calculation
- Laser angle measurement system and correction function (Option)
- AP Bending support (Option)
- Deadpoint and motorized calculation
- Special application support
- Backup data - Resolve issues via remote access

DELEM DA-69T
3-12 Axis
Option



TOP PUNCH HOLDERS

- Precision, positioning and alignment
- Maximum speed and safety
- Horizontal or vertical die change
- Maximum efficiency

**QUICK
CLAMPING PROMECAM**

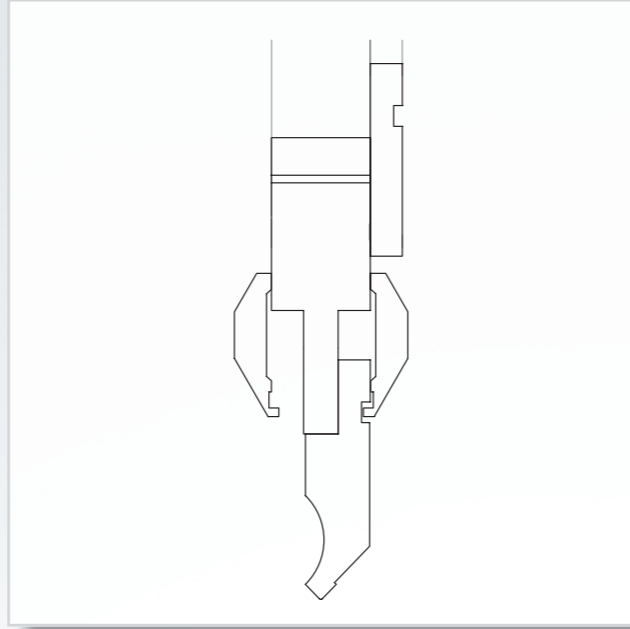

**NARROW TYPE
DIE HOLDER**



60mm veya 90mm Avrupa tipi alt kalıp tutucu.

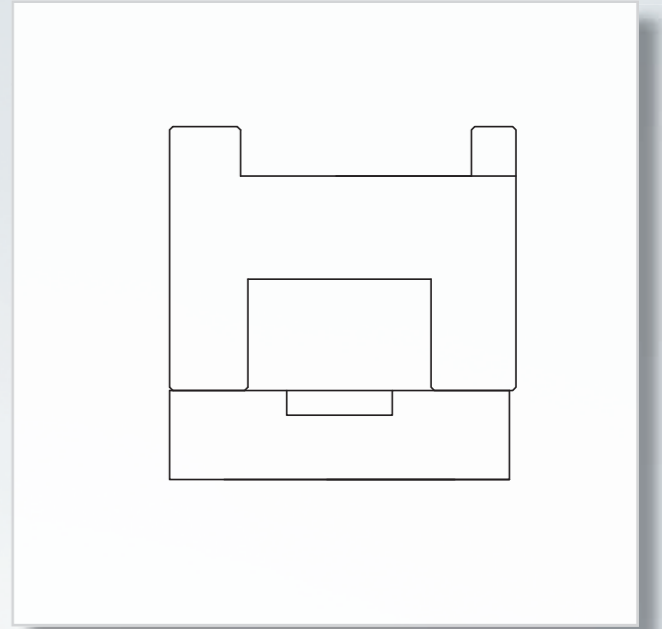

**WILA NSCL
HYDRAULIC DIE CLAMPING**

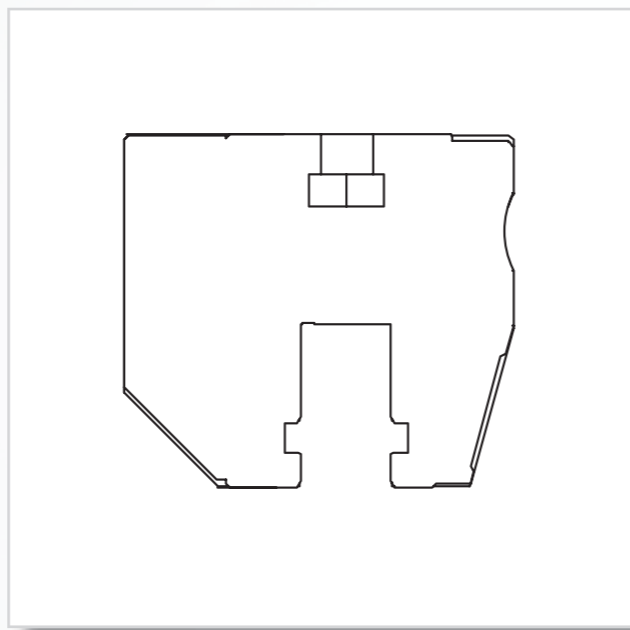
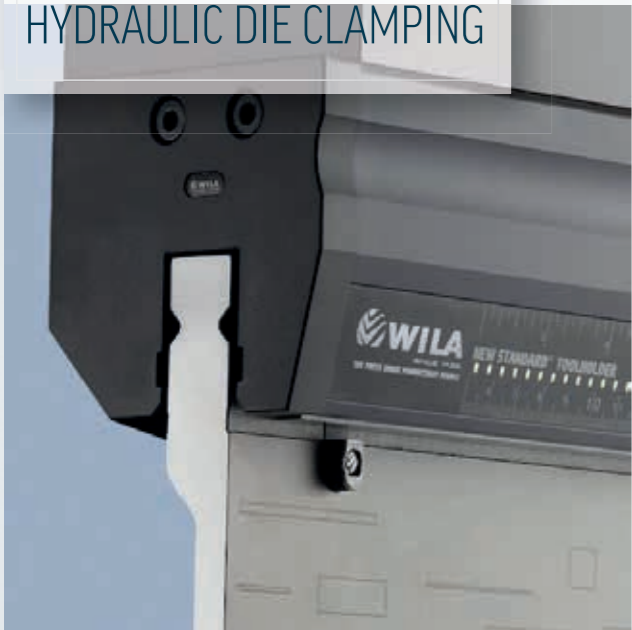

**WILA NSCR
HYDRAULIC DIE HOLDER**

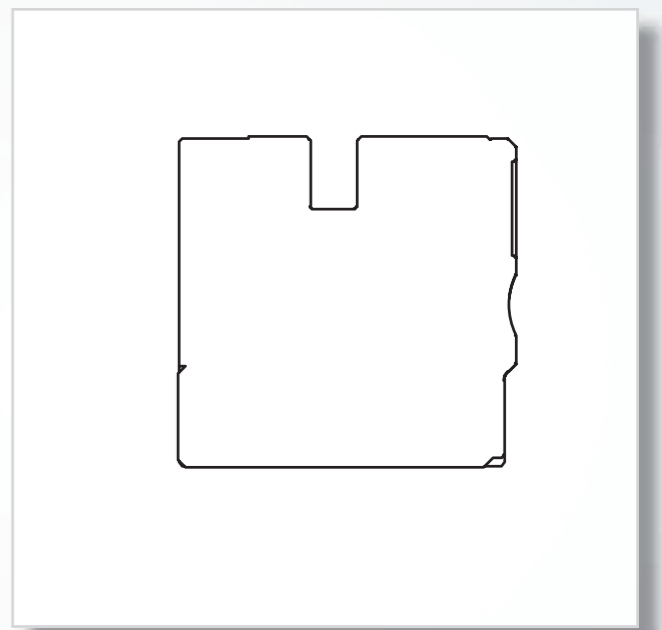

BACK GAUGE OPTIONS

X + R AXIS BACK GAUGE



X travel 750mm, R travel 250mm - Reinforced R Axis with linear sliding



X1, X2, Z1, Z2+X5 AXIS BACK GAUGE



X travel 750mm, R travel 250mm - X5 travel 200mm (± 100 mm) Z1, Z2 travel up to back gauge length



X1, X2, Z1, Z2 AXIS BACK GAUGE



X travel 750mm, R travel 250mm - Z1, Z2 travel up to back gauge length



X1, X2, R1, R2, Z1, Z2 ATF AXIS BACK GAUGE

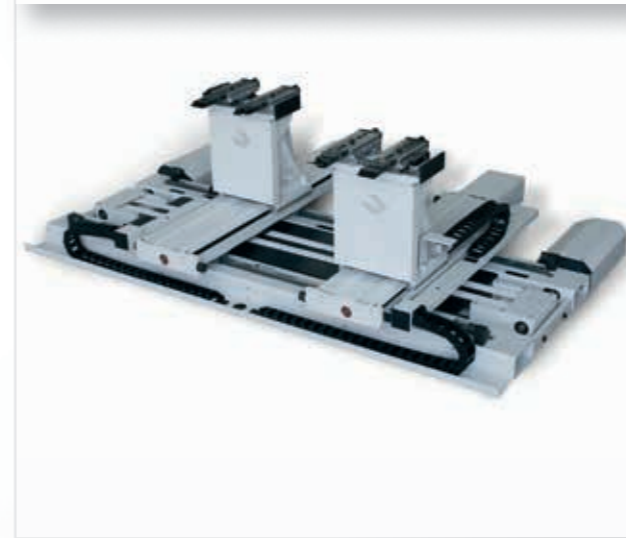

6 Axis tower type back gauge system - High resistance design against impacts.



OTHER OPTIONS

LASER CHECK
AUTO ANGLE CALCULATING SYSTEM

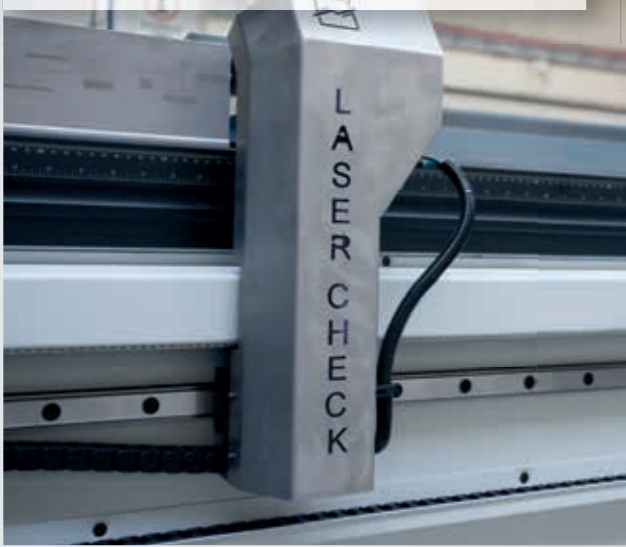

BENDINGLASER
BENDING LINE LASER



CABIN COOLER
AIR-CONDITIONED COOLING SYSTEM



MOTORIZED
CROWNING SYSTEM



PNEUMATIC
REAR SHEET METAL SUPPORT ARMS



AP01 / AP02
FRONT SHEET METAL SUPPORT ARMS

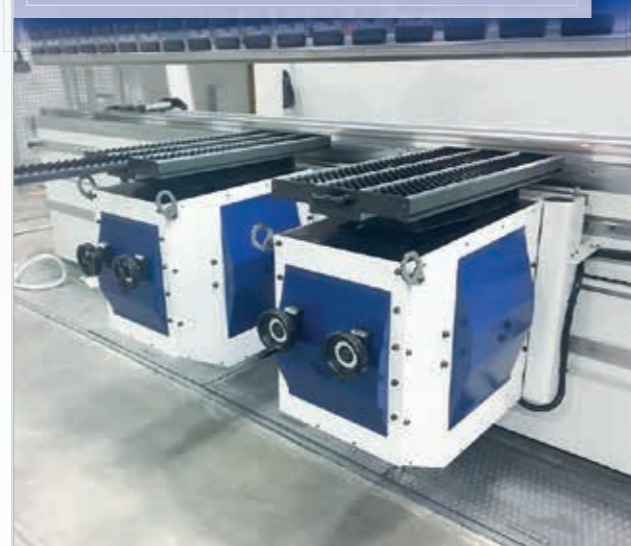

MITUTOYO
ANGLE CALCULATING DEVICE



SAFETY OPTIONS

AKAS II
LASER FRONT SAFETY



AKAS III
LASER FRONT SAFETY



DSP
LASER FRONT SAFETY



REAR SAFETY
LASER COVER



AKAS FPSC
LASER FRONT SAFETY



MSD
LASER FRONT SAFETY



CAGE



REAR SAFETY
LASER BEAM

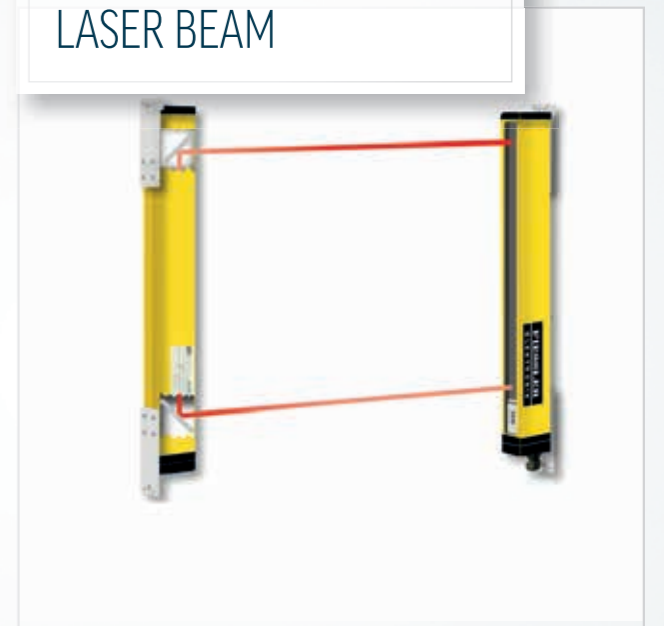

TOP PUNCH

1260

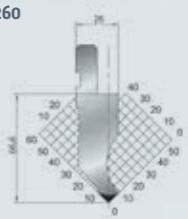

85° / H: 66,6 / R: 0,8 / Max T/m: 100

1281

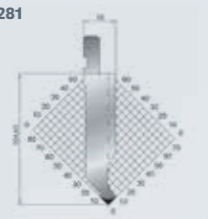

85° / H: 104,65 / R: 0,8 / Max T/m: 100

1172

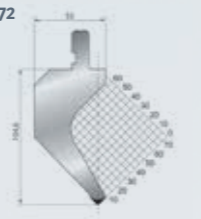

85° / H: 104,65 / R: 0,8 / Max T/m: 50

1309

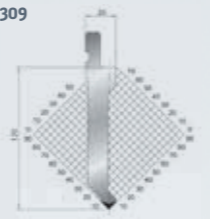

85° / H: 120 / R: 0,8 / Max T/m: 70

1196



24° / H: 128 / R: 0,6 / Max T/m: 80

1036



H: 67 / Max T/m: 100

1055

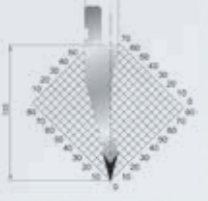

30° / H: 105 / R: 0,5 / Max T/m: 50

1262

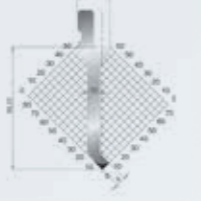

88° / H: 99,35 / R: 0,25 / Max T/m: 50

1061



88° / H: 120 / R: 0,8 / Max T/m: 50

3177

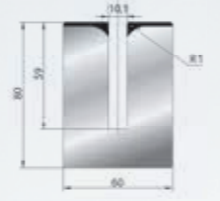

24° / H: 80 / R: 10,1 / Max T/m: 50

1107

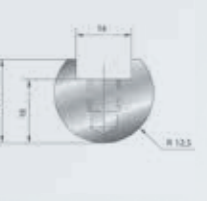

R: 12,5

1270

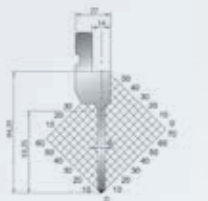

88° / H: 94,35 / R: 0,25 / Max T/m: 50

805 mm Pieced Top Die Set

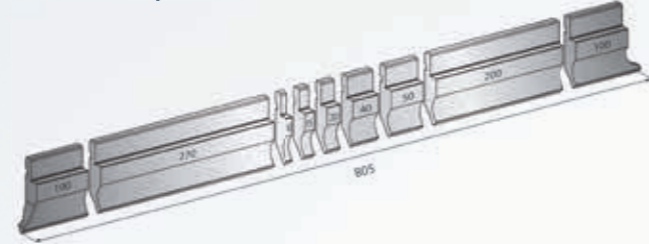

BOTTOM DIE

2067

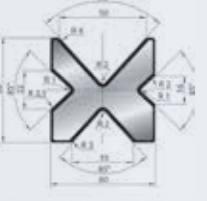

85° / H: 60 / V: 16/22/35/50 / Max T/m: 80

2025

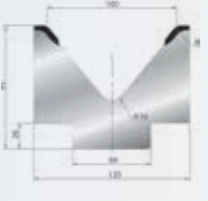

80° / H: 95 / V: 100 / Max T/m: 120

3015

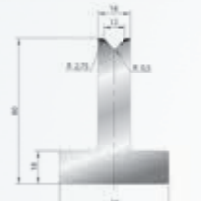

88° / H: 80 / V: 12 / Max T/m: 100

3055

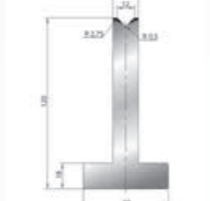

88° / H: 120 / V: 12 / Max T/m: 100

3076

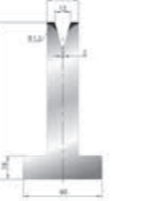

30° / H: 120 / V: 12 / Max T/m: 40

805 mm Pieced Bottom Die Set

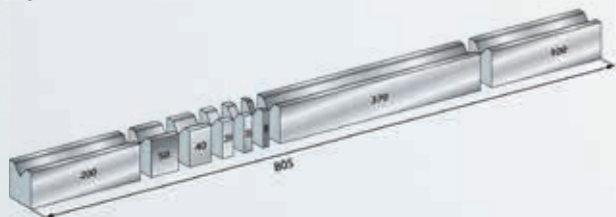

BENDING TABLE

V(mm)	4	6	8	10	12	16	20	24	30	40	50	60	80	100	120	160
V(inc)	0,157"	0,236"	0,315"	0,394"	0,472"	0,630"	0,787"	0,945"	1,181"	1,575"	1,969"	2,362"	3,150"	3,937"	4,724"	6,299"
mm from outside to outside	2,8	4,2	5,6	7	8,6	11,5	14,4	17	21	29	36	42,4	56,5	71	85	114
ri(mm)	0,6	1	1,2	1,5	1,8	2,4	3	3,6	4,5	6	7,5	9	12	15	18	24

Material thickness (mm)

0,5	4	2																	
1		10	8	5,5	4,5														
1,2		16	12	9	7														
1,5			20	14	11	8	6												
2					22	15	11	9,5											
2,5						25	19	15	11										
3							28	22	17	12									
4								44	22	22,5	17								
5									55	37	29	22							
6										58	42	34							
8											83	65	45	35					
10												110	75	57	45				
12													116	85	68				
14														121	91	68			
15															143	112	79		
16																168	131	90	
18																	172	119	
20																		222	150
25																			254

$$F = \frac{S^2 \times 2 \times TS}{1.4 \times V} = \dots \text{ ton/m}$$

TONNAGE PER METER

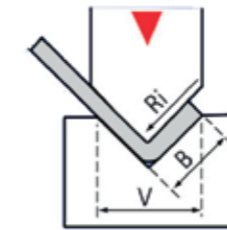

TS: Tensile Strength
(Steel 42 kg/mm²)

TOP PUNCH HOLDERS

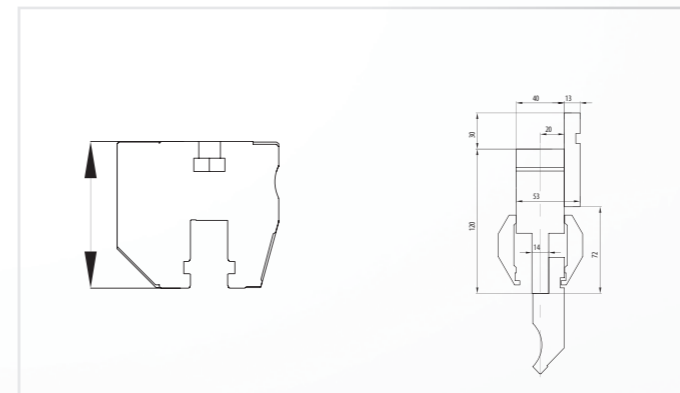

WILA NSCL-I-HC

MVD QUICK CLAMPING
PROMECAM

BOTTOM DIE HOLDERS

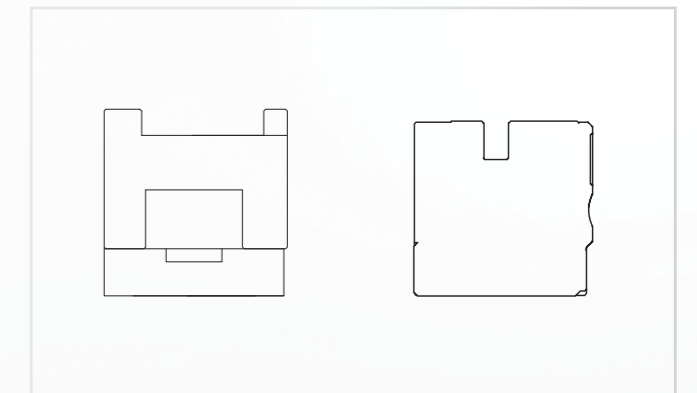

NARROW TYPE

WILA NSCR-I-HC

OUR SERVICES

POWER



With our experience from the past and vision of the future, MVD is your strongest solution partner for your business.

ON TIME DELIVERING



With our flexible team, we are delivering on promised time!

TRUST



As MVD, trust is one of the most important principle of us, so you can see it in our cooperation and in our reliable machines.

AFTER SALES SUPPORT



With our service team, spare part stocks and operator trainings our products are MVD brand's assurance for many years.

INNOVATION



We are investing to improve MVD Quality.

R&D



MVD develops technology for the future...

QUALITY



MVD offers quality to its solution partners by producing "World Class" machines.

TRAINING



We offer advanced operator training for the efficient use of our machines.

SPARE PART SERVICE



We will never let you down! Our service is always available for you!

CONSULTANCY



Since we know the all industries, we assist you with the right choice.

CUSTOMIZED OFFERS



We compose special offers according to the needs of our solution partners.

PRODUCTIVITY



Under our quality assurance we produce machines for increase your productivity.

DESIGN

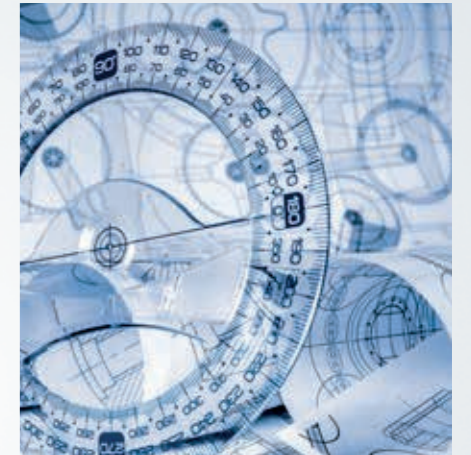

We involve innovative works carefully in our machines.



TRUSTED PARTNER

FULLY 
ELECTRICAL



OUR PRODUCTS





JPS Machinery Ltd
Metalworking Technologies

 **UK**
Sole Distributor

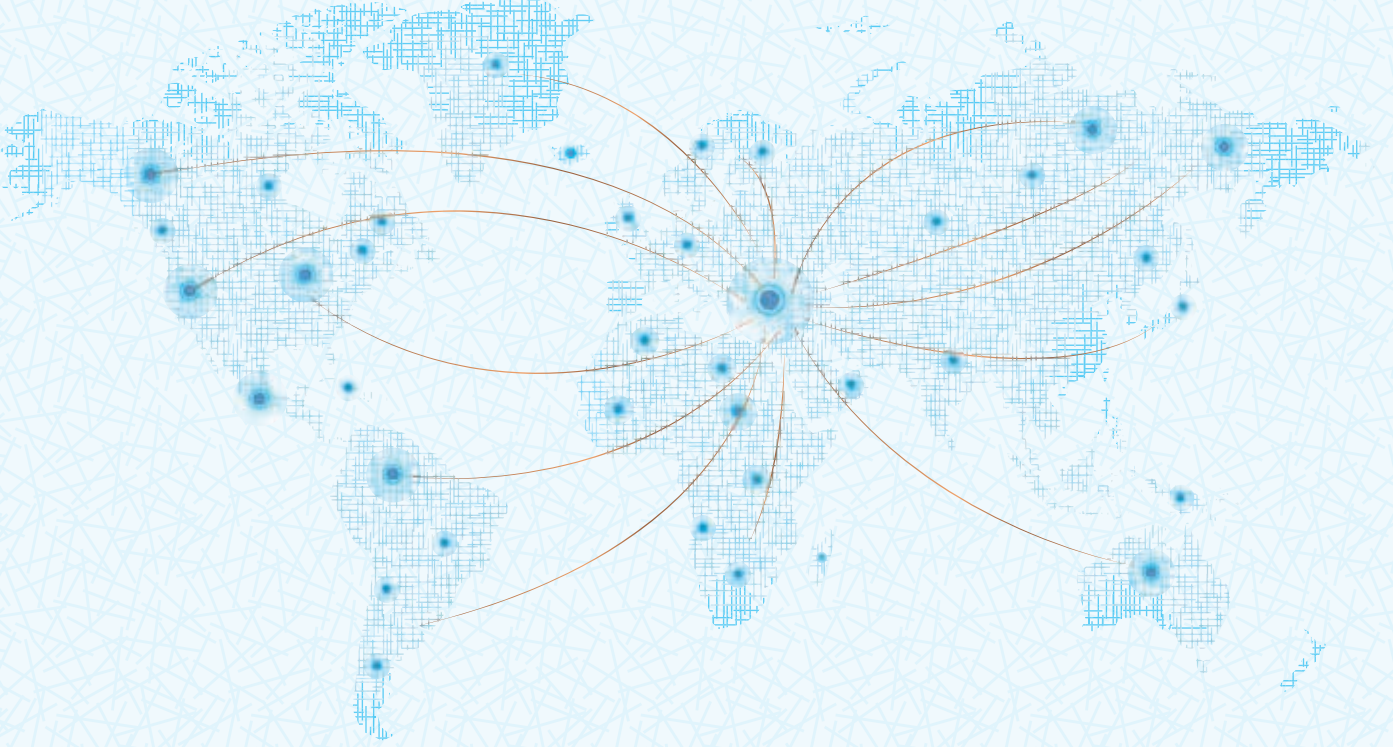

www.mvd.com.tr

 **MVD** | **MVD Makina** Sanayi A.Ş. **MVD Inan** Takım Tezgahları Sanayi A.Ş.

 +90 332 239 2233 (pbx)

 +90 332 239 21 21

 37° 58' 59" N, 32° 36' 34" E

 www.mvd.com.tr

 info@mvd.com.tr

 Konya Organize Sanayi Bölgesi Evrenköy Cad.1 Nolu Sokak No: 3 42050 Konya / Türkiye

 **MVD USA** | **MVD USA** Inc.

 +1 847 350 1865

 +90 332 239 21 21

 41°58'49.6"N 87°59'12.0"W

 www.mvd-usa.com

 info@mvd.com.tr

 901 Mittel Drive, Wood Dale, ILLINOIS, USA 60191



MVDMakina