AFFORDABLE TECHNOLOGY

PRCB performance level is comparable only on machines with much higher standards. These press brakes may be configurable with different equipment to enhance their performance at all levels.

FUTURE IS NOW

PRCB

HIGH PERFORMANCE



RICO[®]
Precision Ideas

RICO's PRCB are versatile, even in their basic configuration, and offer an enviable price/performance ratio.

Their performance level was so far available only on machines with much higher specifications and price levels. They are also evolutionary press brakes, which according to the needs of each user may be equipped with different equipment and devices to enhance their performance and productivity.

PRCB
TECHNOLOGY AND PRECISION
MORE ACCESSIBLE

Using all the technology RICO, **PRCB** model combines quality, performance and accuracy at a competitive price.



MAK- ING FUTU RE



TABLE OF CONTENTS

	PAGE
.01 PRCB Range	5
.02 Standard equipment	6
.03 Optional equipment	7
.04 RICO Green	18
.05 Machinery with Tandem integration	20
.06 Robotized cells integration	21
.07 RICO Press brakes range	22
.08 Technical specifications	24
.09 Bending table	25



MAIN ADVANTAGES

- .01 / High precision and repeatability
- .02 / Extremely quick cycle times
- .03 / Customizable
- .04 / Excellent dimensional characteristics
- .05 / 2 years warranty



PRCB FULLY CONFIGURABLE

PRCB range is fully configurable following the customer's need. The standard range features models with capacities varying from 30 to 600 ton. Furthermore, RICO is capable of building machinery with different configurations upon customers' request.

MOST COMMON CUSTOMIZATION
STROKE, DAYLIGHT, THROAT DEPTH, SIDE FRAMES
DISTANCE.

PRCB RANGE

LENGTH (mm) CAPACITY	1600	2100	2600	3100	3600	4100	6100
30 TON	●	●					
70 TON		●	●	●			
100 TON		●	●	●	●	●	●
135 TON				●	●	●	●
160 TON				●	●	●	●
200 TON				●	●	●	●
250 TON				●	●	●	●
300 TON				●	●	●	●
400 TON					●	●	●
450 TON					●	●	●
500 TON					●	●	●
600 TON						●	●

NOTES: - All models allow its integration in robotic cells.
- All models may be used in Tandem or Tridem system.
- Capacity with more than 600 Ton available under request.

AFTER SALES SERVICE

RICO enriches its service by means of quality and proximity to the customer. The competence and experience acquired as manufacturer are key factors for the solutions provided and results achieved.

Being RICO's customer is to have a service of excellence on previous and after-sale counseling and support. We believe that technical assistance is vital to the best equipment performance and, as such, we decided to **provide free lifelong training to all our customer's since 2007.**

We guarantee immediate intervention for

all emergencies, both regarding mechanical failure as well as training or clarification of doubts. We employ highly skilled and experienced technicians to provide customer's with the best advice, searching for the best metal plate cutting and shaping solutions.

We provide our customer's with qualified technical service, always working with the following goals:

- PROBLEMS SOLUTION AT THE FIRST CONTACT;
- QUICK ANSWER;
- ASSURED QUALITY.



EQUIPMENT

The right machine configuration is essential to achieve maximum efficiency taking into account the type of intended use.

We make proposals with **detailed configuration** and based on **customer requirements**

STANDARD ^S

TYPE	ITEM	PRCB	PAGE
Control panel	Delem DA-53T control	●	8
Automatic axes	3 automatic axes: Y1+Y2+X	●	9
Back gauge	BGA back gauge (up to 200 Ton)	●	9
	BGAH back gauge (more than 200 Ton)	●	9
Front safety	LASER AKAS II-F	●	9
Rear safety	Safety barriers (Level IV)	●	-
Special systems	Standby function	●	18
Supports	SFS front support	●	10
Top clamping	Manual clamping	●	14
Bottom clamping	Manual clamping	●	14
Offline software	Profile TL	●	17
Others	Hanging swivel in control panel	●	-
	Machine LED status	●	6
	Hex key set	●	-

● Standard ○ Optional

^S Machine LED status



CHOOSING IS IMPORTANT

The purpose of each option is to **get the return that is higher than its cost**. For this, it's important to evaluate the return that will be obtained taking into account the work that is intended to accomplish in the future.



OPTIONAL

TYPE	ITEM				PAGE	
Control panel	DELEM	CYBELEC				
	DA-58T	CybTouch 8/12 PS				
	DA-66T	Modeva DNC 15			8	
	DA-69T	Modeva 19T Modeva RA Premium				
Automatic axes	R	Z1+Z2	X5		9	
Back gauge	BGT with 6 automatic axes				9	
Safety lasers	AKAS II-M	AKAS 3P	Iris		9	
Angle measurers	React	Iris Plus	eyeV		15	
Front supports	SFA	SFH			10	
Rear supports	SPA				11	
Follower supports	ACFA	ACF1	ACF2		11	
Top clamping	MANUAL	PNEUMATIC		HYDRAULIC		
	Speed Grip M	Speed Grip P				
	FR-M	FR-P			14	
	Wila M	Wila PN	Wila HYD			
Bottom clamping	CROWNING		CLAMPING			
		CNC	MANUAL	MANUAL	PNEUMATIC	HYDRAULIC
	RICO	○	○	ROL2 M	ROL2 PN	ROL2 HYD
WILA	○	○	○	○	○	
LED tool locator	RICO LedBar	Wila Smart Tool Locator			15	
Tool identification	WILA TIPS				15	
Tool cabinet	ARM1	ARM2	ARM1A		17	
Offline software	Delem Profile T2D	Delem Profile T3D	RICOBend		17	
Others	S-Boost				16	

EQUIPMENT

. CONTROLS

DELEM								
	DA-53T ^S	DA-58T	DA-66T	DA-69T	DA-66T	DA-69T	DA-69T	DA-69T
Axes	4	4	4	4	8	8	8	8
Screen	10"	7"	15"	12"	17"	19"	17"	15"
2D graphic view	-	-	●	●	●	●	●	●
3D graphic view	-	-	-	-	●	○	●	●
3D programming	-	-	-	-	-	○	●	●
Auto tooling selection	-	-	-	●	●	-	●	●
Touch screen	●	●	●	●	●	●	●	●
USB ports	1	1	1	1	2	1	2	1
2D DXF import	-	-	-	-	○	-	●	●
3D IGES/STEP offline	-	-	-	-	-	-	●	●
3D offline import	-	-	-	-	●	-	●	●
Export DXF 2D FP	-	-	-	-	-	-	●	●
Offline software	Profile TL	PC Modeva	Profile TL	PC Modeva	Profile TL	PC Modeva	Profile T3D	PC RA Premium

CybTouch 8 PS	CybTouch 12 PS	ModEva 19T	RA PREMIUM

● Standard ○ Optional

CYBELEC

. SAFETY LASERS



FISSLER	AKAS-II F ^S	AKAS-II M	AKAS 3P
Type	Laser	Laser	Laser
Min. muting point distance	11 mm	11 mm	0,5 mm
Automatic "Y" adjustment	-	-	●

. BACK GAUGES

BGA ^S	X ^S	R	Z1	Z2	X5
Stroke (mm)	750 (1000)	150	UNDER REQUEST	UNDER REQUEST	190
Speed (mm/s)	500	170	2000	2000	200
Precision (mm)	± 0,05	± 0,10	± 0,10	± 0,10	± 0,05
Type of motor	BRUSHLESS	BRUSHLESS	BRUSHLESS	BRUSHLESS	BRUSHLESS
Mechanical system	BALL SCREW	RACK	BELT	BELT	BALL SCREW

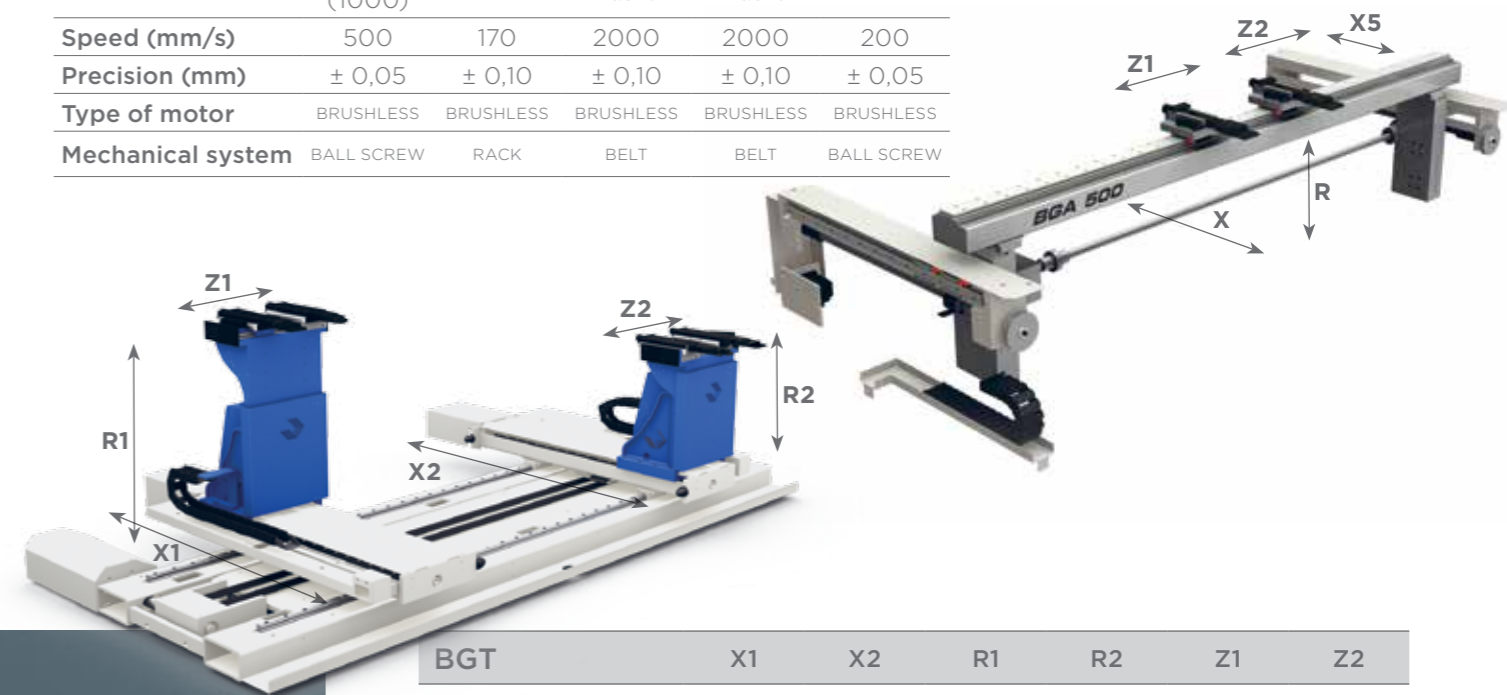

BGT	X1	X2	R1	R2	Z1	Z2
Stroke (mm)	800	800	200	200	UNDER REQUEST	UNDER REQUEST
Speed (mm/s)	600	600	200	200	550	550
Precision (mm)	± 0,05	± 0,05	± 0,05	± 0,05	± 0,10	± 0,10
Type of motor	BRUSHLESS	BRUSHLESS	BRUSHLESS	BRUSHLESS	BRUSHLESS	BRUSHLESS
Mechanical system	RACK	RACK	RACK	RACK	RACK	RACK

SUPPORTS

Sheet supports are auxiliary bending accessories. They must be chosen according to the dimensions and weight of the pieces.

Front supports: Support the plate during the front feed;

Back supports: Support the plate in the approach to the back gauge;

Follower supports: Support the movement of the plate during the bending.

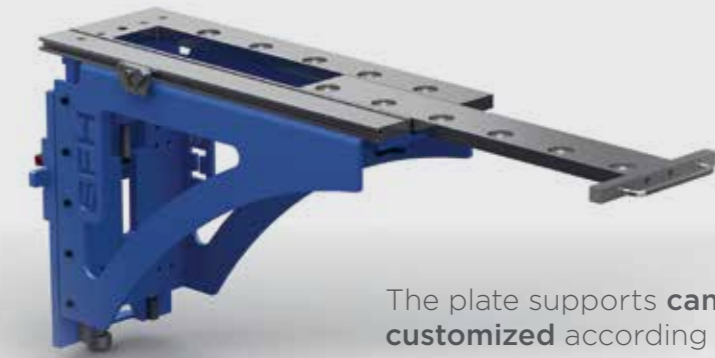

The plate supports **can be customized** according to the customer needs.

FRONTAL SUPPORTS

SFS



- . Supported on any position of the clamps;
- . Manual height regulation;
- . Device for approaching to the die;
- . Load capacity:
 - < 200 Ton: 75 kg per support
 - ≥ 200 Ton: 150 kg per support.

SFA



- . Supported on sliding guides;
- . Can be placed at any point along the length;
- . Manual height regulation;
- . Millimetric scale;
- . Ball transfer units to facilitate handling parts;
- . Adjustable plate stop;
- . Device for approaching to the die;
- . Removable supports;
- . Load capacity:
 - < 200 Ton: 100 kg per support
 - ≥ 200 Ton: 150 kg per support.

SFH



- . Supported on sliding guides;
- . Continuous manual height regulation;
- . Millimetric scale;
- . Ball transfer units to facilitate handling parts;
- . Adjustable plate stop;
- . Load capacity – 2000 kg per support.

REAR SUPPORTS

SPA

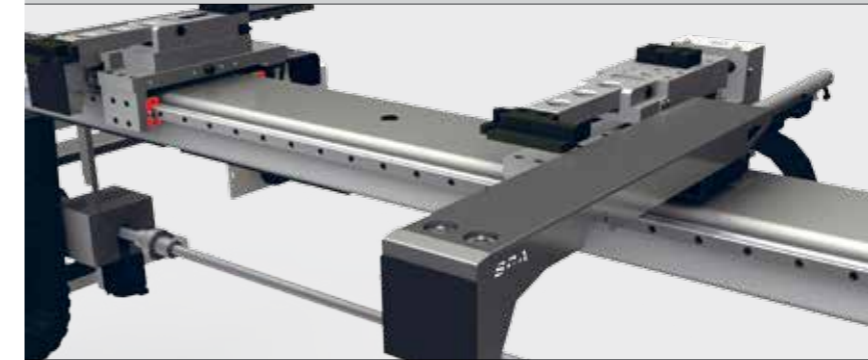

SPA supports are installed in the fingers of the back gauge. They can be activated in pre-defined bending and enable the plate to slide until it lies adjacent to the back gauge.

Load capacity – 30 kg per support.

FOLLOWER SUPPORTS

ACFA



- . Automatic bending follower supports;
- . Controlled by CNC;
- . Recommended for heavy parts or large thin plate;
- . Supported on longitudinal sliding rails;
- . X and Y position adjustment;
- . Load capacity – 180 kg per support.

ACF1 / ACF2

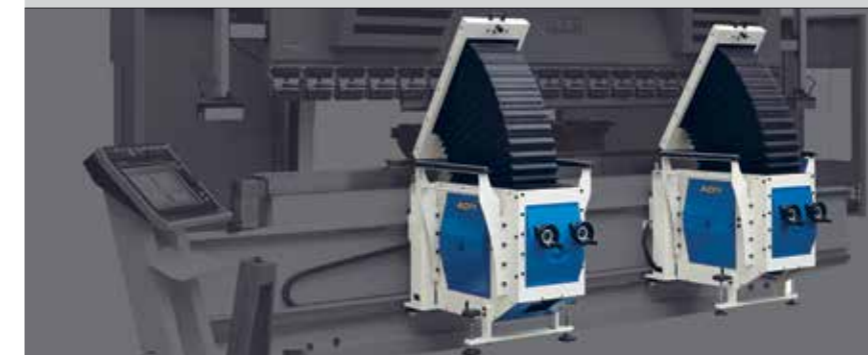

- . Automatic bending follower supports. Controlled by CNC;
- . Recommended for heavy parts or large thin plate;
- . Supported on longitudinal sliding rails;
- . X and Y position adjustment;
- . Load capacity:
 - ACF1: 160 kg per support
 - ACF2: 400 kg per support.



PRCB

TOP CUSTOMIZATION

To meet all customer requirements, **PRCB is a fully configurable machine.** This versatility goes from sizing to optional equipment.

IS NOW

. QUICK CLAMPING

When there are frequent tooling changes, punches or dies can be changed over in a short time by using the quick clamps. **The time saved will be higher as more often will be necessary to change tools.**

In all top clamping the punches can be removed directly from the front, so it is not necessary to slide it on one side. This operation compared to conventional **allows a reduction of times greater than 8x.**

TOP QUICK CLAMPING	PROMECAM SYSTEM			WILA SYSTEM	
	CLAMP			CLAMP	
	Manual	Pneumatic		Manual	Hydraulic/Pneumatic*
					
	FR-M	FR-P		NSCL-I-MC PRO	NSCL-I-HC PRO
					
SPEED GRIP	SPEED GRIP PN		NSCL-II-MC PREMIUM	NSCL-II-HC PREMIUM	
					
BOTTOM QUICK CLAMPING	PROMECAM SYSTEM			WILA SYSTEM	
	CLAMP			CLAMP	
	Manual	Pneumatic	Hydraulic	Manual	Hydraulic/Pneumatic*
					
	ROL2	ROL PN	ROL HYD	NSCR-I-MC PRO	NSCR-I-HC PRO
					
			NSCR-II-MC PREMIUM	NSCR-II-HC PREMIUM	
					

* Under request.

. LED TOOL LOCATOR

LedBar is a bending aid that helps the operator to position the tools and parts during the bending process.

RICO LedBar



WILA Smart Tool Locator





. WILA TOOL IDENTIFICATION AND POSITIONING SYSTEM (TIPS)

The **WILA TIPS** system is an integrated part of the press brake control system that helps to identify tools and to continuously read their position. The tools are localized and identified irrespective of whether they are located in the upper clamping, lower clamping or storage system.



. ANGLE MEASURERS

MODEL	REACT	IRIS PLUS	LASERCHECK (10 / 11 / 12)
Type			
	Protractor	Camera	Laser
Active correction	-	●	●
Accuracy	± 0,1°	up to 0,25°	± 0,1°
Max. V die	-	35 mm	200 mm

. CROWING TABLE

This system **enables the user to offset deformations of the beam while bending.** By this, the angle remains constant throughout the length. The compensating arc is accurately calculated taking

into account the design of the machine and its deformations under load. The process is automatic and the calculation takes into account the thickness of the sheet, type of material, opening of the V and length.

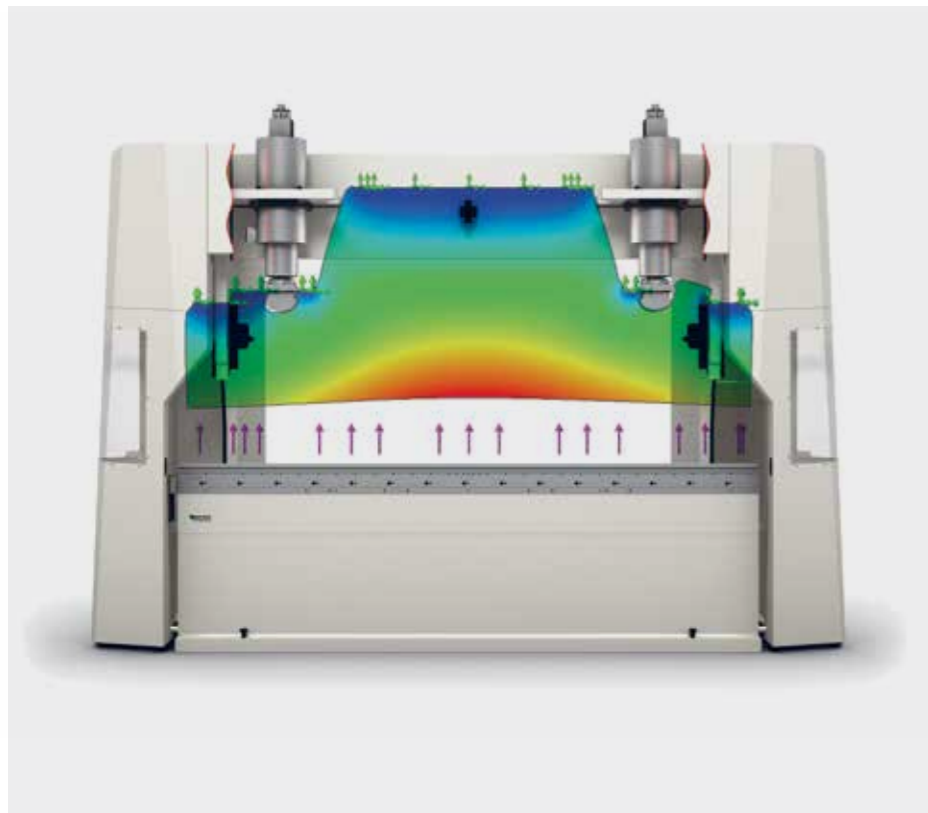

PROMECAM



WILA



. TOOL CABINET

	Shelves	Sliding shelves
Arm1	4	-
Arm2	8	-
Arm1A	4	●



. OFFLINE SOFTWARE

Offline software is an indispensable tool to increase the profitability of a machine. **All RICO machines have offline software included** depending on the machine control.

In the case of 3D software's allow the import of the 2D / 3D files automatically realizing the programming of the bending and creating a file for the cut.

	2D	3D
Profile TL ^S	●	-
Profile T2D	●	-
Profile T3D	●	●
PC Modeva	●	●
PC RA Premium	●	●
Radbend	●	●



. S-BOOST

Increased productivity is a major goal of today's enterprises. **S-Boost is a system that offers a greater fast speed up and down.**

S-boost 1 up to 200 Ton

S-boost 2 from 200 to 300 Ton



NOTE: Speed values with S-Boost are described on page 24.

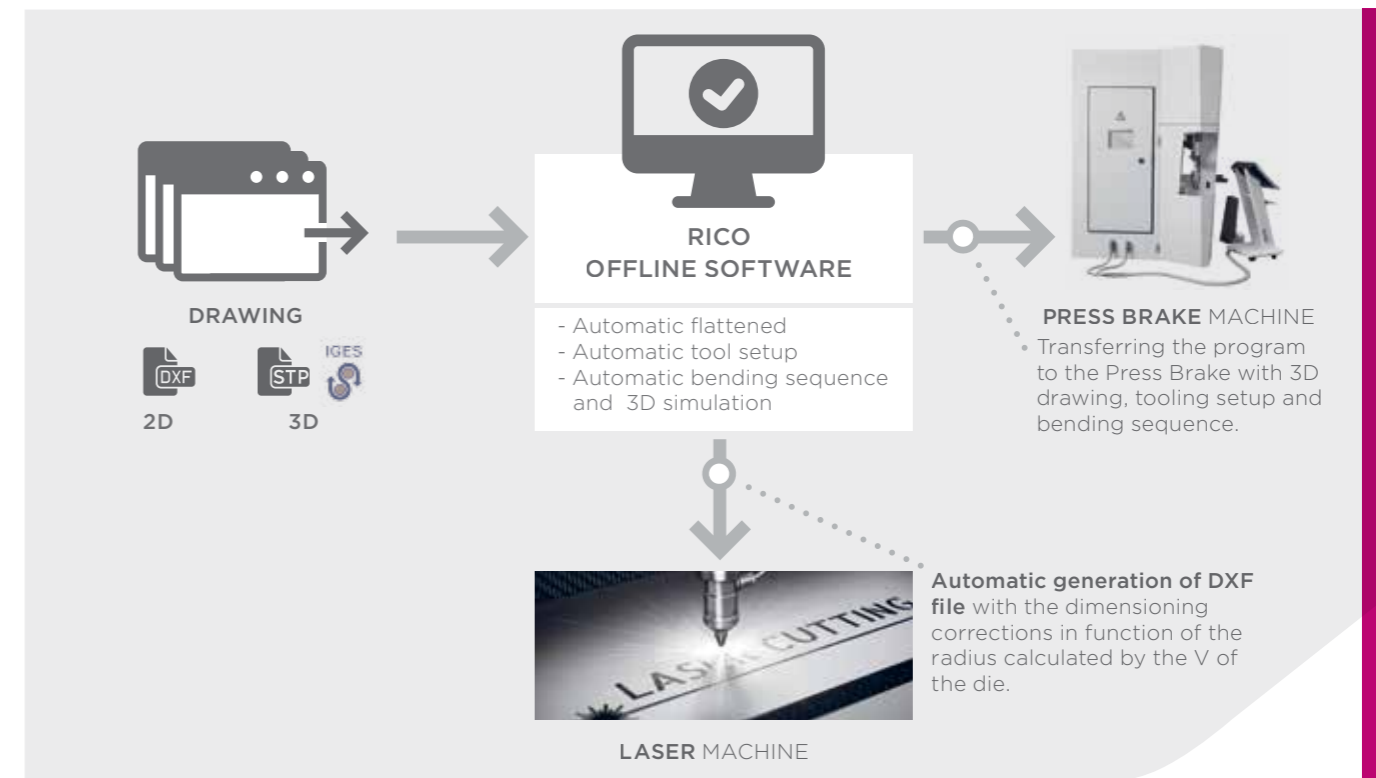

RICO GREEN

RICO promotes a friendly environmental policy, and, as such, all our equipment features the Standby Function. This function leads to the **automatically stop of the power after 5 consecutive minutes of inactivity.** Standby Function ensures an effective economy of energy on an automatic basis.

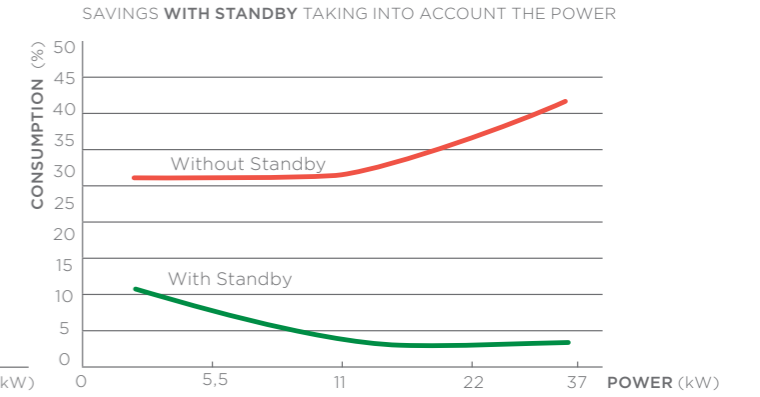
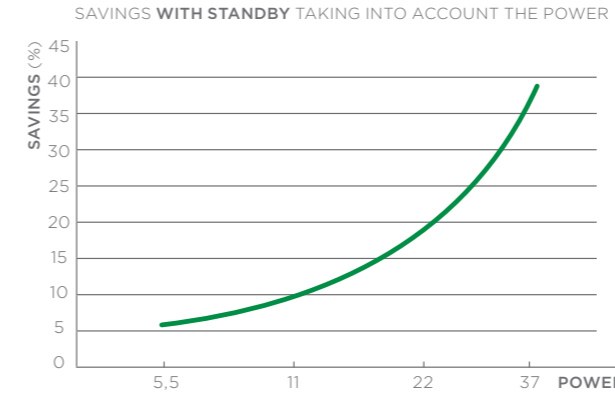

**Standby
FUNCTION**

75%
IDLE SAVING

20%
EFFECTIVE SAVINGS

BE
PAPER

**RICO GREEN
INTEGRATED NATURE**

Developing in line with sustainability and environmental concern.

TANDEM INTEGRATION

Two press brakes may be used in tandem when bending large lengths.

This system enables the user to synchronise the two machines to guarantee the same speed and precision.

The Tandem system enables the two machines to be operated in **simultaneous or stand-alone mode.**

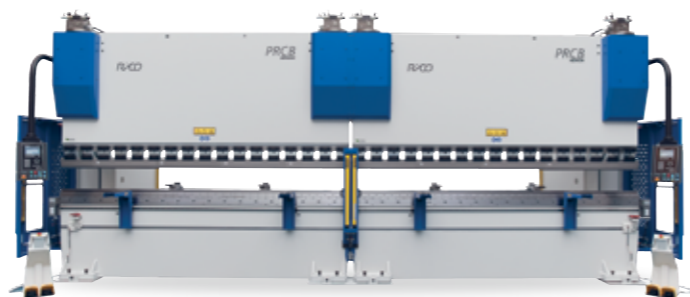

RICO INTEGRATED CELLS

The PRCB press brake is designed to allow for the introduction of robotic cells developed in accordance with the needs of each project.

PRESS BRAKES RANGE

RICO offers 4 models of Press Brakes with different configuration but with a common characteristic: **high quality**. The choice of the model must take into account the purpose and the advantage of its use.

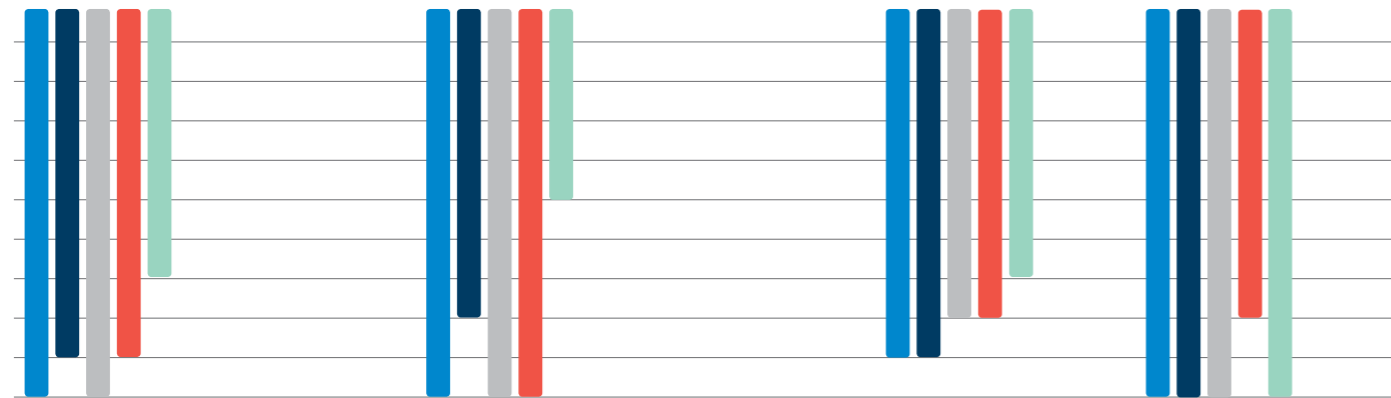

- Accuracy
- General speed's
- Structural Performance
- Stroke range
- Energy efficiency

OTHER ELEMENTS

	STANDARD CONTROL	STANDARD AXES	SWAYBEND	H-BOX FRAME	TRIPLE GUIDE
PRCB	Delem DA-53T	3	-	-	-
PRCN I-LINE	Delem DA-66T	4	●	●	●
PRCN C-LINE	Delem DA-66T	4	●	●	●
PRCE	Delem DA-53T	4	-	-	-



RICO MORE INNOVATION

RICO strategy purpose is **sustainable growth** to ensure a constant investment in innovation, resulting in added value for us and for our customers.

FUTURE FORWARD

Embrace future challenges, and give our contribution to help industries getting prepared to the next step, is RICO's main commitment.

Day-to-day operations are important, but long-term business strategy will determine the ongoing and further success. Building a reliable board of principles will help to ensure that our **vision for the future will be carried forward**.

KNOW-HOW

Nearly 50 years of expertise in the manufacture of press brakes and guillotines machines give us the security that is needed for future challenges.

TRUST + RELIABILITY

High standards of quality and a team with the best training and knowledge are a major condition for our success. Our products are the result of a continued focus on improving internal processes underpinned by high quality levels, that result in the recognition of RICO's machines as quality guarantee equipment.

SUSTAINABLE GROWTH

The purpose of RICO strategy is sustainable growth that can ensure a constant investment in innovation, which results in added value for the customer, to create good conditions for its employees and respects the environment.

TECHNICAL SPECIFICATIONS

	Bending length		Throat depth	Beam stroke	Daylight	Daylight 2 *	Fast	Bending	Return (RS)	RS S-Boost *	Oil capacity	Back gauge stroke	Motor power	Total length (A)	Total height (B)	Total width (C)	Distance between frames	Height under the floor	Approx. weight
	mm	Ton																	
	mm/s		Lts	mm	mm		mm/s		mm		mm		mm		mm		mm		Kg
PRCB 1530	1600	30	300	280	480	520	210	0-10/20*	140	230	75	600	4	2520	2550	1790	1220	0	3280
PRCB 2030	2100	30	300	280	480	520	210	0-10/20*	140	230	75	600	4	2900	2550	1790	1600	0	3570
PRCB 2070	2100	70	300	280	480	520	210	0-10/18*	145	220	120	750	7,5	2860	2745	1985	1600	0	5800
PRCB 2570	2600	70	300	280	480	520	210	0-10/18*	145	220	120	750	7,5	3360	2745	1985	2100	0	6300
PRCB 3070	3100	70	300	280	480	520	210	0-10/18*	145	220	120	750	7,5	3860	2745	1985	2600	0	7000
PRCB 20100	2100	100	400	280	480	520	200	0-10/18*	145	220	180	750	11	2880	2780	2040	1600	0	6800
PRCB 25100	2600	100	400	280	480	520	200	0-10/18*	145	220	180	750	11	3380	2780	2040	2100	0	7430
PRCB 30100	3100	100	400	280	480	520	200	0-10/18*	145	220	180	750	11	3880	2780	2040	2600	0	8120
PRCB 35100	3600	100	400	280	480	520	200	0-10/18*	145	220	180	750	11	4380	2780	2040	3100	0	9280
PRCB 40100	4100	100	400	280	480	520	200	0-10/18*	145	220	180	750	11	4880	2780	2040	3100	0	10000
PRCB 60100	6100	100	400	280	480	520	200	0-10/18*	125	200	180	750	11	6960	3120	1950	5100	0	19000
PRCB 30135	3100	135	400	280	480	520	200	0-10/17*	135	200	230	750	11	3900	2885	1710	2600	0	9900
PRCB 35135	3600	135	400	280	480	520	200	0-10/17*	135	200	230	750	11	4400	2885	1710	3100	0	10600
PRCB 40135	4100	135	400	280	480	520	200	0-10/17*	135	200	230	750	11	4900	2885	1710	3100	0	11100
PRCB 60135	6100	135	400	280	480	520	200	0-10/17*	115	180	230	750	11	6980	3180	1950	5100	0	20000
PRCB 30160	3100	160	400	280	480	520	200	0-10/17*	155	205	230	750	15	3910	2935	1780	2600	0	10470
PRCB 35160	3600	160	400	280	480	520	200	0-10/17*	155	205	230	750	15	4400	2935	1780	3100	0	11940
PRCB 40160	4100	160	400	280	480	520	200	0-10/17*	155	205	230	750	15	4900	2935	1780	3100	0	12460
PRCB 60160	6100	160	400	280	480	520	200	0-10/17*	135	195	230	750	15	6980	3290	2000	5100	0	24100
PRCB 30200	3100	200	400	280	480	520	200	0-10/17*	130	200	290	750	15	3930	2935	1920	2600	0	12580
PRCB 35200	3600	200	400	280	480	520	200	0-10/17*	130	200	290	750	15	4420	2935	1920	3100	0	13240
PRCB 40200	4100	200	400	280	480	520	200	0-10/17*	130	200	290	750	15	4920	2935	1920	3100	0	14450
PRCB 60200	6100	200	400	280	480	520	200	0-10/17*	110	180	290	750	15	7000	3500	2000	5100	1150	27000
PRCB 30250	3100													3940	3435	1955	2600	0	15150
PRCB 35250	3600	250	400	330	550	590	180	0-10/17*	130	205	390	750	19	4440	3435	1955	3100	0	15650
PRCB 40250	4100	250	400	330	550	590	180	0-10/17*	130	205	390	750	19	4940	3435	1955	3100	0	16200
PRCB 60250	6100	250	400	330	550	590	180	0-10/17*	110	195	390	750	19	7020	3770	2100	5100	1200	33600
PRCB 30300	3100	300	400	330	550	590	180	0-10/17*	130	205	470	750	30	3960	3435	1955	2600	0	16360
PRCB 35300	3600	300	400	330	550	590	180	0-10/17*	130	205	470	750	30	4460	3435	1955	3100	0	17300
PRCB 40300	4100	300	400	330	550	590	180	0-10/17*	130	205	470	750	30	4960	3435	1955	3100	0	18000
PRCB 60300	6100	300	400	330	550	590	180	0-10/17*	110	195	470	750	30	7040	3770	2200	5100	1200	37000
PRCB 35400	3600	400	400	380	600	640	170	0-10	120	-	380	750	30	4480	3720	2300	3100	0	22900
PRCB 40400	4100	400	400	380	600	640	170	0-10	120	-	380	750	30	4980	3720	2300	3100	0	23900
PRCB 60400	6100	400	400	380	600	640	170	0-10	100	-	380	750	30	7060	3900	2450	5100	1350	39500
PRCB 35450	3600	450	400	380	600	640	150	0-10	105	-	380	750	30	4480	3720	2300	3100	0	23700
PRCB 40450	4100	450	400	380	600	640	150	0-10	105	-	380	750	30	4980	3720	2300	3100	0	24800
PRCB 60450	6100	450	400	380	600	640	150	0-10	90	-	380	750	30	7060	3880	2450	5100	1350	41300
PRCB 35500	3600	500	400	380	600	640	140	0-10	105	-	380	750	30	4500	3790	2450	3100	0	26000
PRCB 40500	4100	500	400	380	600	640	140	0-10	105	-	380	750	30	5100	3790	2450	3100	0	27600
PRCB 60500	6100	500	400	380	600	640	140	0-10	90	-	380	750	30	7080	4050	2530	5100	1700	43700
PRCB 40600	4100	600	400	430	650	690	130	0-10	115	-	600	750	45	5000	3960	2650	3100	900	32300
PRCB 60600	6100	600	400	430	650	690	130	0-10	100	-	600	750	45	7080	4140	2650	5100	1700	45000

* Optional

Content subject to change without notice. V3.04

BENDING TABLE

Required bending power (Ton/m)

Rm=420 N/mm² - Rm=700 N/mm²

R	B	V	S (mm)																		
			0,5	0,6	0,8	1	1,2	1,5	2	2,5	3	4	5	6	8	10	12	15	20	25	30
0,5	3	4	4 ₇	6 ₁₀	12 ₂₀																
0,7	3,5	5	3 ₅	5 ₈	9 ₁₅	15 ₂₅															
0,8	4	6	2 ₄	3 ₆	7 ₁₂	11 ₁₉	18 ₃₀														
1	5,5	8		2 ₄	5 ₈	8 ₁₃	12 ₂₁	21 ₃₅													
1,3	6,5	10			4 ₆	6 ₁₀	9 ₁₅	15 ₂₆	30 ₅₀												
1,5	8	12				5 ₈	7 ₁₂	12 ₂₀	23 ₃₈	39 ₆₆											
2	10,5	16					5 ₈	8 ₁₃	16 ₂₆	27 ₄₅	44 ₇₁										
2,5	13	20						6 ₁₀	12 ₁₉	20 ₃₃	31 ₅₂	60 ₁₀₁									
3,2	16,5	25							9 ₁₅	14 ₂₄	23 ₃₈	44 ₇₃	76 ₁₂₆								
4,4	21	32								11 ₁₈	16 ₂₇	32 ₅₃	54 ₉₀	85 ₁₄₂							
5	26	40									12 ₂₁	23 ₃₈	39 ₆₆	62 ₁₀₃	121 ₂₀₂						
6,5	32,5	50										18 ₃₀	29 ₄₈	45 ₇₆	88 ₁₄₇	151 ₂₅₂					
8	41	63											22 ₃₇	33 ₅₅	70 ₁₁₇	109 ₁₈₂	173 ₂₈₈				
10	52	80												25 ₄₂	46 ₇₇	79 ₁₃₁	124 ₂₀₇	213 ₃₅₄			
12	65	100													35 ₅₉	58 ₉₆	91 ₁₅₁	155 ₂₅₈	302 ₅₀₄		
15	81,5	125														44 ₇₄	66 ₁₁₀	113 ₁₈₉	220 ₃₆₇	378 ₆₃₀	
20	104	160															50 ₈₃	81 ₁₃₅	158 ₂₆₃	269 ₄₄₈	425 ₇₀₉
25	130	200																62 ₁₀₄	115 ₁₉₂	197 ₃₂₈	310 ₅₁₇
37	163	250																	89 ₁₄₈	144 ₂₄₀	227 ₃₇₈
45	195	300																		120 ₂₀₀	173 ₂₈₈

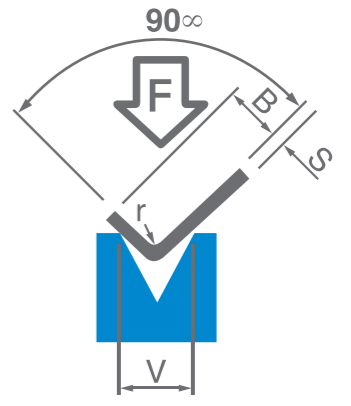

i ALL DIMENSIONS CAN BE DIFFERENT ON CUSTOMIZED MACHINES.

THE DIMENSIONS FOR TRANSPORT CAN BE DIFFERENT.

AGENT\



V. 031712

TOMÁS CASTRO SILVA, LDA.
GONDOMAR | PORTUGAL

Rua de Cerquido - Zebreiros
4515-118 | Foz do Sousa
Portugal

T | +351 224 540 370
F | +351 224 541 424
E | geral@rico.pt

RICO.PT